



SAFE Technical Note 1

How SAFE Calculates Punching Shear For the ACI 318-95 Code

(CSA A23.3-94, NZS 3101-95 and IS 456-1978 R1996 Codes Similar)

The information in this document is consistent with SAFE version 6.14 and later

Initial Release Date: November 16, 1998

Revision Number: 4

Revision Date: June 16, 2000



Table Of Contents

Item	Page
1. Terminology For SAFE Method of Calculating Punching Shear	1
2. Basic Equations For SAFE Method of Calculating Punching Shear	1
3. Limitations of Punching Shear Calculations in SAFE	3
4. Other Comments	4
5. References	4
6. Numerical Example.....	5
a. Problem Statement	5
b. SAFE Computer Model.....	6
c. Hand Calculation For Interior Column Using SAFE Method.....	8
d. Hand Calculation For Edge Column With Edge Parallel To X-Axis Using SAFE Method.....	11
e. Hand Calculation For Edge Column With Edge Parallel To Y-Axis Using SAFE Method.....	14
f. Hand Calculation For Corner Column Using SAFE Method	17
g. Hand Calculation For Corner Column Using SAFE Method Except That I_{XY} Is Set To Zero.....	20
h. Terminology For PCA Publication Method of Calculating Punching Shear	21
i. Basic Equation For PCA Publication Method.....	21
j. Hand Calculation For Interior Column Using PCA Publication Method	22
k. Hand Calculation For Edge Column With Edge Parallel To X-Axis Using PCA Publication Method	24
l. Hand Calculation For Edge Column With Edge Parallel To Y-Axis Using PCA Publication Method	26
m. Hand Calculation For Corner Column Using PCA Publication Method	29
n. Comparison Of Punching Shear Stress Results.....	31

1. Terminology For SAFE Method of Calculating Punching Shear

The following terms are used in describing the SAFE method of calculating punching shear:

- b_0 = perimeter of critical section for punching shear
- d = effective depth at critical section for punching shear based on average of d for X direction and d for Y direction
- I_{XX} = Moment of inertia of critical section for punching shear about an axis that is parallel to the global X-axis
- I_{YY} = Moment of inertia of critical section for punching shear about an axis that is parallel to the global Y-axis
- I_{XY} = Product of inertia of critical section for punching shear with respect to the X and Y planes
- L = Length of side of critical section for punching shear currently being considered
- M_{UX} = Moment about line parallel to X-axis at center of column (positive per right-hand rule)
- M_{UY} = Moment about line parallel to Y-axis at center of column (positive per right-hand rule)
- v_U = Punching shear stress
- V_U = Shear at center of column (positive upward)
- x_1, y_1 = Coordinates of column centroid
- x_2, y_2 = Coordinates of center of one side of critical section for punching shear
- x_3, y_3 = Coordinates of centroid of critical section for punching shear
- x_4, y_4 = Coordinates of location where you are calculating stress
- γ_{VX} = Percent of M_{UX} resisted by shear per ACI 318-95 equations 11-41 and 13-1
- γ_{VY} = Percent of M_{UY} resisted by shear per ACI 318-95 equations 11-41 and 13-1

2. Basic Equations For SAFE Method of Calculating Punching Shear

$$v_U = \frac{V_U}{b_0 d} + \frac{\gamma_{VX}[M_{UX} - V_U(y_3 - y_1)][I_{YY}(y_4 - y_3) - I_{XY}(x_4 - x_3)]}{I_{XX}I_{YY} - I_{XY}^2} - \frac{\gamma_{VY}[M_{UY} + V_U(x_3 - x_1)][I_{XX}(x_4 - x_3) - I_{XY}(y_4 - y_3)]}{I_{XX}I_{YY} - I_{XY}^2} \quad \text{Eq. 1}$$

$$I_{XX} = \sum_{sides=1}^n \bar{I}_{XX}, \text{ where sides refers to the sides of the critical section for punching shear} \quad \text{Eq. 2}$$

$$I_{YY} = \sum_{sides=1}^n \bar{I}_{YY}, \text{ where sides refers to the sides of the critical section for punching shear} \quad \text{Eq. 3}$$

$$I_{XY} = \sum_{sides=1}^n \bar{I}_{XY}, \text{ where sides refers to the sides of the critical section for punching shear} \quad \text{Eq. 4}$$

The equations for \bar{I}_{xx} , \bar{I}_{yy} , and \bar{I}_{xy} are different depending on whether the side of the critical section for punching shear being considered is parallel to the X-axis or parallel to the Y-axis. Refer to Figures 1a and 1b.

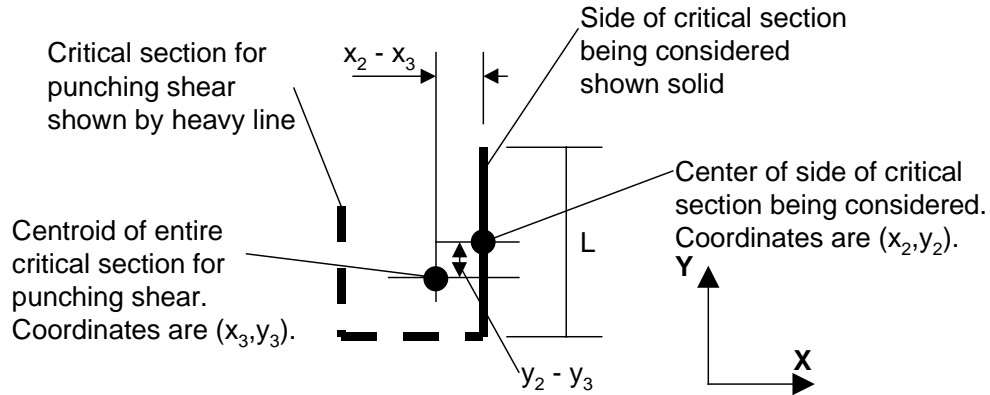

Figure 1b: Plan View For Side of Critical Section Parallel to Y-Axis

Work This Sketch With Equations 5b, 6b and 7

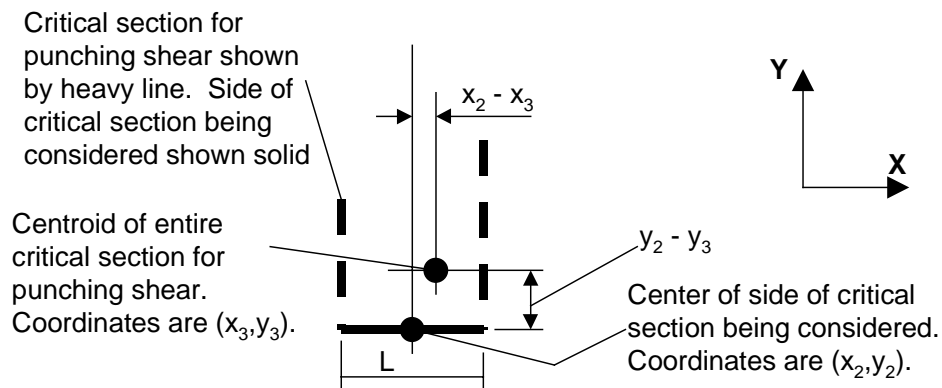

Figure 1a: Plan View For Side of Critical Section Parallel to X-Axis

Work This Sketch With Equations 5a, 6a and 7

$$\bar{I}_{xx} = Ld(y_2 - y_3)^2, \text{ for side of critical section parallel to X-axis} \quad \text{Eq. 5a}$$

$$\bar{I}_{xx} = \frac{Ld^3}{12} + \frac{dL^3}{12} + Ld(y_2 - y_3)^2, \text{ for side of critical section parallel to Y-axis} \quad \text{Eq. 5b}$$

$$\bar{I}_{yy} = \frac{Ld^3}{12} + \frac{dL^3}{12} + Ld(x_2 - x_3)^2, \text{ for side of critical section parallel to X-axis} \quad \text{Eq. 6a}$$

$$\bar{I}_{yy} = Ld(x_2 - x_3)^2, \text{ for side of critical section parallel to Y-axis} \quad \text{Eq. 6b}$$

$$\bar{I}_{xy} = Ld(x_2 - x_3)(y_2 - y_3), \text{ for side of critical section parallel to X-axis or Y-axis} \quad \text{Eq. 7}$$

3. Limitations of Punching Shear Calculations in SAFE

- The shear and moment values used in the punching shear check have not been reduced by the load (or reaction) that is included within the boundaries of the punching shear critical section. Typically the effect of this simplification is small except in some cases for deep slabs (e.g., mat foundations) and slabs with closely spaced columns.
- Punching shear is calculated for columns punching through a slab or a drop panel. It is not calculated for a drop panel punching through a slab. The effect of column capitals is included in the punching shear calculation.
- The program checks that each slab element in the area enclosed between the face of the column and the critical section for punching shear has identically the same slab property label. If so, the punching shear check is performed, if not, punching shear is not calculated and N/C is displayed.
- When line objects (beams, walls or releases) frame into a column, punching shear is not calculated and N/C is displayed.
- If a point load or column falls (call it load/column A) within the critical section for punching shear for another point load or column (call it load/column B), then it is ignored in the punching shear calculation (that is, the effect of load/column A is ignored when doing punching shear calculations for load/column B.)
- The program only considers critical sections for punching shear that have sides parallel to the X and Y axes. Thus when the edge of a slab is not parallel to the X or Y axis, the program may not pick up the worst case critical section for punching shear. For example, in Figure 2, the critical sections for punching shear identified in Cases A and B are considered by SAFE, but CASE C is not considered.

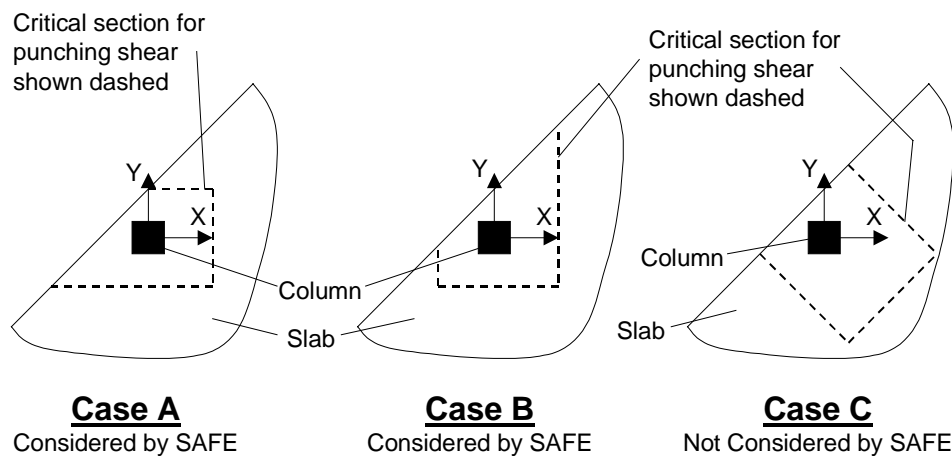

Figure 2: Critical Sections For Punching Shear Considered By SAFE

4. Other Comments

Equation 1 is based on Chapter 8, Section 50 of S. Timoshenko's book titled "Strength of Materials" (Ref. 1) and on the requirements of codes such as ACI 318-95.

For interior columns and edge columns the punching shear formulation used in SAFE yields the same results as those that are obtained using the equations given in Figure 18-16 of the PCA Publication (Ref 2). The results are different for corner columns. The reason for the difference is the I_{XY} term that is included in the SAFE equations but not in the PCA equations. For interior columns and edge columns the I_{XY} term included in the SAFE formulation reduces to zero. The I_{XY} term is nonzero for corner columns because the X and Y axes are not the principal axes for this section. If the I_{XY} term in the SAFE equations is set to zero, then the SAFE equations yield the same results for corner columns as the PCA equations. (Note that there is no way to actually set the I_{XY} term to zero in SAFE.) It could be argued that the SAFE formulation is perhaps more theoretically sound than the equations given in the PCA Publication. The net effect of the I_{XY} term is to make the SAFE punching shear calculation for corner columns a little more conservative than that given in the PCA Publication.

5. References

1. S. Timoshenko, 1958
Strength of Materials, Part I, 3rd Edition, D. Van Nostrand Company, New York, New York.
2. PCA, 1996
Notes On ACI 318-95 Building Code Requirements For Structural Concrete With Design Applications, Portland Cement Association, Skokie, Illinois.

6. Numerical Example

6a. Problem Statement

The numerical example is a flat slab with drop panels that has three 24' spans in each direction, as shown in Figure 3. The slab overhangs beyond the face of the column by 6" along each side of the structure. The columns are typically 12" x 36" with the long side parallel to the Y-axis. The slab is typically 10" thick. At the drop panels there is an additional 5" of slab thickness, thus the total slab thickness at the drop panels is 15". The plan dimensions of the interior drop panels are 8' x 8', the edge drop panels where the edge is parallel to the X-axis are 8' x 6', the edge drop panels where the edge is parallel to the Y-axis are 5' x 8', and the corner drop panels are 5' x 6'.

The concrete has a unit weight of 150 pcf and a f'_c of 4000 psi. The dead load consists of the self weight of the structure plus an additional 20 psf. The live load is 80 psf.

Thick plate properties are used for the slab.

Each column in Figure 3 is referenced with a number. For example, the column at the intersection of grid lines A and 1 is number 5. These numbers refer to the point object ID's in the associated SAFE model

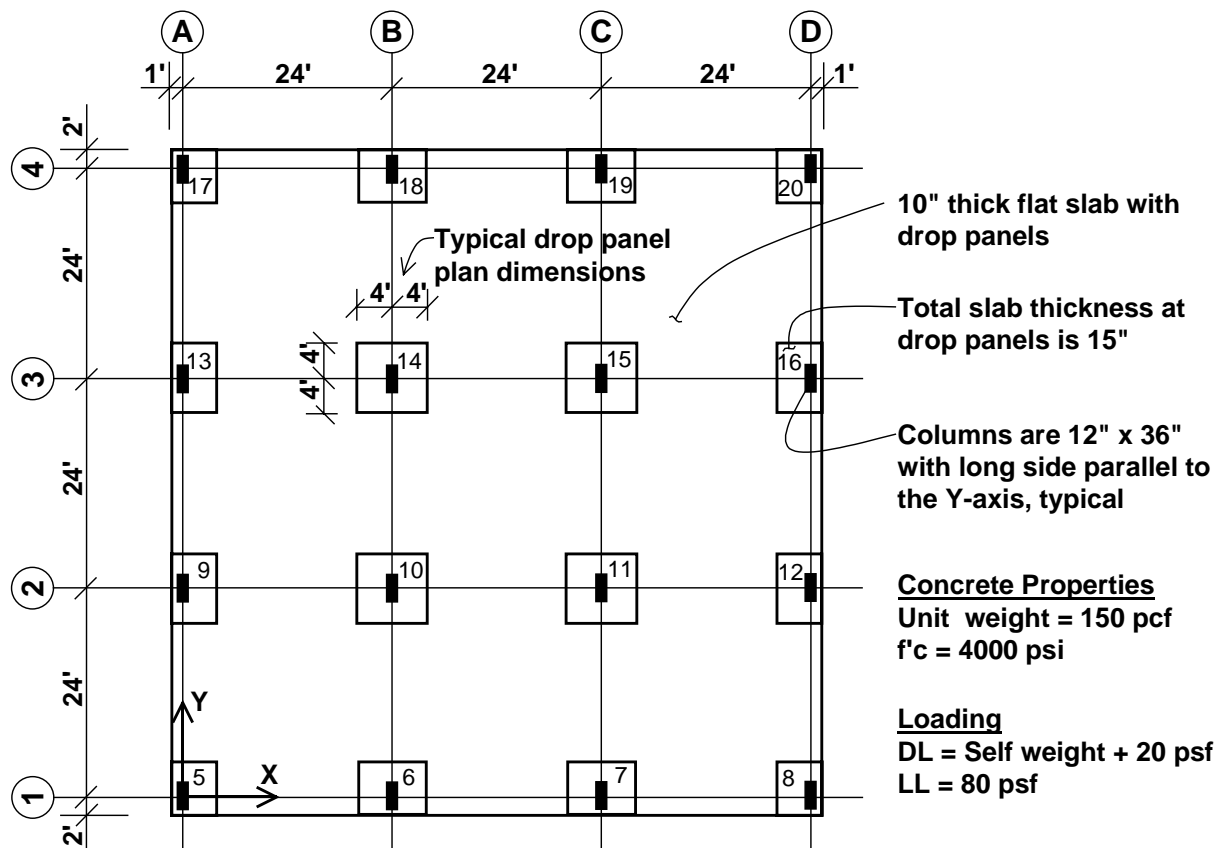

Figure 3: Flat Slab With Drop Panels For Numerical Example



6b. SAFE Computer Model

In SAFE it is easy to create a computer model for this example, analyze it, design it, and print out the punching shear results. The following steps are required:

1. Set the units to kips and feet.
2. From the File menu select New Model From Template, and then click on the Flat Slab button to display the Flat Slab dialog box.
3. In this dialog box:
 - Change the Top Edge Distance and Bottom Edge Distance to 2.
 - Check the Create Live Load Patterns check box.
 - Accept the rest of the default values and click the OK button.
4. From the Define menu select Slab Properties to display the Support Properties dialog box. Highlight the property named COL, click the Modify\Show Property button to display the Slab Property Data dialog box, check the Thick Plate check box and click OK. Highlight the property named DROP, click the Modify\Show Property button to display the Slab Property Data dialog box, check the Thick Plate check box and click OK. Highlight the property named SLAB, click the Modify\Show Property button to display the Slab Property Data dialog box, check the Thick Plate check box and click OK twice to exit all dialog boxes.
5. From the Define menu select Column Supports to display the Support Properties dialog box. With the support property named COLUMN highlighted click the Modify\Show Property button to display the Column Support Property Data dialog box. In this dialog box change the Y Dimension to 3. Accept the rest of the default values and click the OK button twice to exit all dialog boxes.
6. The SAFE model is now created and ready to run. From the Analyze menu select Run Analysis. Select a directory and provide a name for the input file and then click the Save button to proceed with the analysis.
7. When the analysis is completed review the messages in the Analysis window and click the OK button. The model is now ready for design.
8. From the Options menu select Preferences and click the Concrete tab. Verify that the Concrete Design Code selected is ACI 318-95. If necessary, change the selection to this code. Click the OK button to exit this dialog box.
9. From the Design menu select Start Design.

10. When the design is complete click Display Punching Shear Ratios on the display menu to show the punching shear results graphically.
11. Change the units to kips and inches.
12. From the File menu select Print Design Tables to display the Design Tables dialog box.
- 13 In this dialog box:
 - In the Design Output area uncheck the Slab Strip Reinforcing check box and check the Punching Shear check box.
 - In the Design Forces area uncheck the Slab Strip check box.
 - Check the Print To File check box. Note that the default name for this file is the name of your model with a .txt extension. Accept this default name.
 - Click the OK button to create the punching shear output.

The punching shear output is now in a text file whose name is the same as your input file with the extension .txt. You can open this text file in any text editor or word processor, or you can use the Display Input/Output Text Files feature on the File menu in SAFE to open it. This feature opens the file in Wordpad, a text editor that is supplied with Windows. If you open this text file in a word processor or a spreadsheet it should look similar to that shown in Figure 4.

```
SAFE v6.14 File: PUNCHEX Kip-in Units PAGE 1
November 14,1998 7:59
```

P U N C H I N G S H E A R S T R E S S C H E C K												
POINT	X	Y	RATIO	COMBO	VMAX	VCAP	V	MX	MY	DEPTH	PERIM	LOC
5	0.00	0.00	1.000	DCON2	0.179	0.179	-54.696	-1962	1145.680	13.500	73.500	C
6	288.00	0.00	0.802	DCON2	0.144	0.179	-119.738	-3778	-348.558	13.500	123.000	E
7	576.00	0.00	0.802	DCON2	0.144	0.179	-119.738	-3778	348.558	13.500	123.000	E
8	864.00	0.00	1.000	DCON2	0.179	0.179	-54.696	-1962	-1146	13.500	73.500	C
9	0.00	288.00	0.515	DCON2	0.092	0.179	-94.860	174.953	1463.801	13.500	99.000	E
10	288.00	288.00	0.702	DCON2	0.126	0.179	-225.707	464.658	-419.712	13.500	150.000	I
11	576.00	288.00	0.702	DCON2	0.126	0.179	-225.707	464.658	419.712	13.500	150.000	I
12	864.00	288.00	0.515	DCON2	0.092	0.179	-94.860	174.953	-1464	13.500	99.000	E
13	0.00	576.00	0.515	DCON2	0.092	0.179	-94.860	-174.953	1463.801	13.500	99.000	E
14	288.00	576.00	0.702	DCON2	0.126	0.179	-225.707	-464.658	-419.712	13.500	150.000	I
15	576.00	576.00	0.702	DCON2	0.126	0.179	-225.707	-464.658	419.712	13.500	150.000	I
16	864.00	576.00	0.515	DCON2	0.092	0.179	-94.860	-174.953	-1464	13.500	99.000	E
17	0.00	864.00	1.000	DCON2	0.179	0.179	-54.696	1962.206	1145.680	13.500	73.500	C
18	288.00	864.00	0.802	DCON2	0.144	0.179	-119.738	3777.943	-348.558	13.500	123.000	E
19	576.00	864.00	0.802	DCON2	0.144	0.179	-119.738	3777.943	348.558	13.500	123.000	E
20	864.00	864.00	1.000	DCON2	0.179	0.179	-54.696	1962.206	-1146	13.500	73.500	C

Figure 4: SAFE Output For Punching Shear

Following are explanations of each of the column headings in the output shown in Figure 4:

- POINT = SAFE point object ID at location where punching shear stress is reported
 X = X-coordinate of POINT

- Y = Y-coordinate of POINT
- RATIO = Punching shear stress divided by punching shear capacity
- COMBO = Load combination that produces maximum punching shear stress
- VMAX = Punching shear stress with the maximum absolute value
- VCAP = Punching shear stress capacity with a phi factor included, i.e., ϕv_c
- V = Shear used in punching shear stress calculation
- MX = Moment about a line through the column centroid and parallel to the X-axis used in punching shear stress calculation
- MY = Moment about a line through the column centroid and parallel to the Y-axis used in punching shear stress calculation
- DEPTH = Effective depth for punching shear calculated as the average of the effective depths in the X and Y directions
- PERIM = Perimeter length of critical section for punching shear
- LOC = Identifier for column location: I is an interior column, E is an edge column, and C is a corner column

We will now derive some of the results shown in Figure 4 using hand calculations. The results we will calculate are the shear stress, shear capacity and the shear ratio for an interior column, an edge column with the edge parallel to the X-axis, an edge column with the edge parallel to the Y-axis, and a corner column. We will calculate these values using the SAFE formulation and then calculate them again using the formulation in the PCA Publication (Ref 2). Finally, we will compare the results obtained from SAFE, our hand calculations using the SAFE formulation, and our hand calculations using the PCA Publication formulation.

6c. Hand Calculation For Interior Column Using SAFE Method

$$d = [(15 - 1) + (15 - 2)] / 2 = 13.5''$$

Refer to Figure 5.

$$b_0 = 49.5 + 25.5 + 49.5 + 25.5 = 150''$$

$$\gamma_{VX} = 1 - \frac{1}{1 + \left(\frac{2}{3}\right)\sqrt{\frac{49.5}{25.5}}} = 0.482$$

$$\gamma_{VY} = 1 - \frac{1}{1 + \left(\frac{2}{3}\right)\sqrt{\frac{25.5}{49.5}}} = 0.324$$

The coordinates of the center of the column (x_1, y_1) are taken as (0, 0).

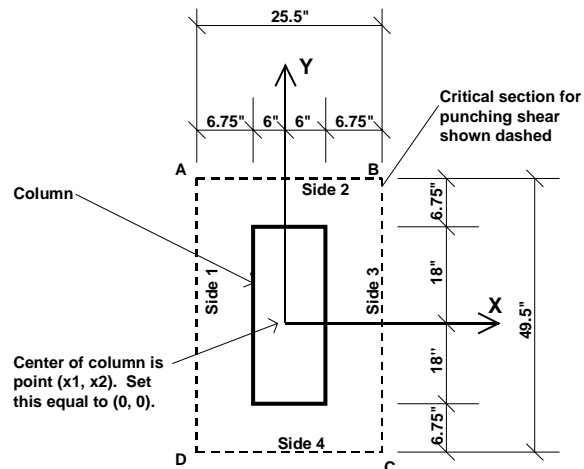

Figure 5: Interior Column, Point 10 in SAFE Model

The following table is used for calculating the centroid of the critical section for punching shear. Side 1, Side 2, Side 3 and Side 4 refer to the sides of the critical section for punching shear as identified in Figure 5.

Item	Side 1	Side 2	Side 3	Side 4	Sum
x_2	-12.75	0	12.75	0	N.A.
y_2	0	24.75	0	-24.75	N.A.
L	49.5	25.5	49.5	25.5	$b_0 = 150$
d	13.5	13.5	13.5	13.5	N.A.
Ld	668.25	344.25	668.25	344.25	2025
Ldx_2	-8520.19	0	8520.19	0	0
Ldy_2	0	8520.19	0	-8520.19	0

$$x_3 = \frac{\sum Ldx_2}{Ld} = \frac{0}{2025} = 0"$$

$$y_3 = \frac{\sum Ldy_2}{Ld} = \frac{0}{2025} = 0"$$

The following table is used to calculate I_{XX} , I_{YY} and I_{XY} . The values for I_{XX} , I_{YY} and I_{XY} are given in the column titled "Sum".

Item	Side 1	Side 2	Side 3	Side 4	Sum
L	49.5	25.5	49.5	25.5	N.A.
d	13.5	13.5	13.5	13.5	N.A.
$x_2 - x_3$	-12.75	0	12.75	0	N.A.
$y_2 - y_3$	0	24.75	0	24.75	N.A.
Parallel to	Y-Axis	X-axis	Y-Axis	X-axis	N.A.
Equations	5b, 6b, 7	5a, 6a, 7	5b, 6b, 7	5a, 6a, 7	N.A.
I_{XX}	146597	210875	146597	210875	714944
I_{YY}	108633	23882	108633	23882	265030
I_{XY}	0	0	0	0	0

From the SAFE output at column point 10:

$$V_U = -225.707 \text{ k}$$

$$M_{UX} = 464.658 \text{ k-in}$$

$$M_{UY} = -419.712 \text{ k-in}$$

At the point labeled A in Figure 5, $x_4 = -12.75$ and $y_4 = 24.75$, thus:

$$v_U = \frac{-225.707}{150 * 13.5} + \frac{0.482[464.658 - (-225.707)(0 - 0)][265030(24.75 - 0) - (0)(-12.75 - 0)]}{(714944)(265030) - (0)^2} - \frac{0.324[-419.712 - (-225.707)(0 - 0)][714944(-12.75 - 0) - (0)(24.75 - 0)]}{(714944)(265030) - (0)^2}$$

$$v_U = -0.111 + 0.008 - 0.007 = -0.110 \text{ ksi at point A}$$

At the point labeled B in Figure 5, $x_4 = 12.75$ and $y_4 = 24.75$, thus:

$$v_U = \frac{-225.707}{150 * 13.5} + \frac{0.482[464.658 - (-225.707)(0 - 0)][265030(24.75 - 0) - (0)(12.75 - 0)]}{(714944)(265030) - (0)^2} - \frac{0.324[-419.712 - (-225.707)(0 - 0)][714944(12.75 - 0) - (0)(24.75 - 0)]}{(714944)(265030) - (0)^2}$$

$$v_U = -0.111 + 0.008 + 0.007 = -0.097 \text{ ksi at point B}$$

At the point labeled C in Figure 5, $x_4 = 12.75$ and $y_4 = -24.75$, thus:

$$v_U = \frac{-225.707}{150 * 13.5} + \frac{0.482[464.658 - (-225.707)(0 - 0)][265030(-24.75 - 0) - (0)(12.75 - 0)]}{(714944)(265030) - (0)^2} - \frac{0.324[-419.712 - (-225.707)(0 - 0)][714944(12.75 - 0) - (0)(-24.75 - 0)]}{(714944)(265030) - (0)^2}$$

$$v_U = -0.111 - 0.008 + 0.007 = -0.113 \text{ ksi at point C}$$

At the point labeled D in Figure 5, $x_4 = -12.75$ and $y_4 = -24.75$, thus:

$$v_U = \frac{-225.707}{150 * 13.5} + \frac{0.482[464.658 - (-225.707)(0 - 0)][265030(24.75 - 0) - (0)(-12.75 - 0)]}{(714944)(265030) - (0)^2} - \frac{0.324[-419.712 - (-225.707)(0 - 0)][714944(-12.75 - 0) - (0)(-24.75 - 0)]}{(714944)(265030) - (0)^2}$$

$$v_U = -0.111 - 0.008 - 0.007 = -0.126 \text{ ksi at point D}$$

Point D has the largest absolute value of v_u , thus $v_{\max} = 0.126 \text{ ksi}$

The shear capacity is calculated based on the smallest of ACI 318-95 equations 11-35, 11-36 and 11-37 with the b_0 and d terms removed to convert force to stress.

$$\phi_{v_c} = \frac{0.85 \left(2 + \frac{4}{36/12} \right) \sqrt{4000}}{1000} = 0.179 \text{ ksi per equation 11-35}$$

$$\phi_{VC} = \frac{0.85 \left(\frac{40 * 13.5}{150} + 2 \right) \sqrt{4000}}{1000} = 0.301 \text{ ksi per equation 11-36}$$

$$\phi_{VC} = \frac{0.85 * 4 * \sqrt{4000}}{1000} = 0.215 \text{ ksi per equation 11-37}$$

Equation 11-35 yields the smallest value of $\phi_{VC} = 0.179 \text{ ksi}$, and thus this is the shear capacity.

$$\text{Shear Ratio} = \frac{v_u}{\phi_{VC}} = \frac{0.126}{0.179} = 0.702$$

6d. Hand Calculation For Edge Column With Edge Parallel To X-Axis Using SAFE Method

$$d = [(15 - 1) + (15 - 2)] / 2 = 13.5''$$

Refer to Figure 6.

$$b_0 = 48.75 + 25.5 + 48.75 = 123''$$

$$\gamma_{VX} = 1 - \frac{1}{1 + \left(\frac{2}{3} \right) \sqrt{\frac{48.75}{25.5}}} = 0.480$$

$$\gamma_{VY} = 1 - \frac{1}{1 + \left(\frac{2}{3} \right) \sqrt{\frac{25.5}{48.75}}} = 0.325$$

The coordinates of the center of the column (x_1, y_1) are taken as (0, 0).

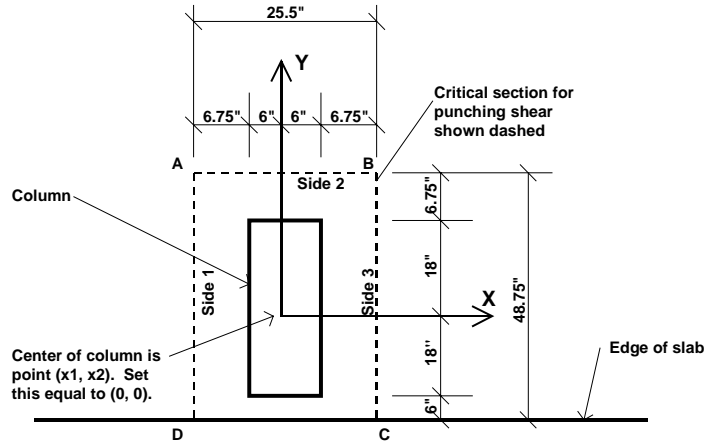

Figure 6: Edge Column With Edge Parallel To X-Axis, Point 6 in SAFE Model

The following table is used for calculating the centroid of the critical section for punching shear. Side 1, Side 2 and Side 3 refer to the sides of the critical section for punching shear as identified in Figure 6.

Item	Side 1	Side 2	Side 3	Sum
x_2	-12.75	0	12.75	N.A.
y_2	0.375	24.75	0.375	N.A.
L	48.75	25.5	48.75	$b_0 = 123$
d	13.5	13.5	13.5	N.A.
Ld	658.125	344.25	658.125	1660.5
Ldx_2	-8391.09	0	8391.09	0
Ldy_2	246.80	8520.19	246.80	9013.78

$$x_3 = \frac{\sum Ldx_2}{Ld} = \frac{0}{1660.5} = 0''$$

$$y_3 = \frac{\sum Ldy_2}{Ld} = \frac{9013.78}{1660.5} = 5.43''$$

The following table is used to calculate I_{XX} , I_{YY} and I_{XY} . The values for I_{XX} , I_{YY} and I_{XY} are given in the column titled "Sum".

Item	Side 1	Side 2	Side 3	Sum
L	48.75	25.5	48.75	N.A.
d	13.5	13.5	13.5	N.A.
$x_2 - x_3$	-12.75	0	12.75	N.A.
$y_2 - y_3$	-5.05	19.32	-5.05	N.A.
Parallel to	Y-Axis	X-axis	Y-Axis	N.A.
Equations	5b, 6b, 7	5a, 6a, 7	5b, 6b, 7	N.A.
I_{XX}	157141	128518	157141	442800
I_{YY}	106986	23883	106986	237855
I_{XY}	42403	0	-42403	0

From the SAFE output at column point 6:

$$V_U = -119.738 \text{ k}$$

$$M_{UX} = 3778 \text{ k-in}$$

$$M_{UY} = -348.588 \text{ k-in}$$

At the point labeled A in Figure 6, $x_4 = -12.75$ and $y_4 = 24.75$, thus:

$$v_U = \frac{-119.738}{123 * 13.5} + \frac{0.480[3778 - (-119.738)(5.43 - 0)][237855(24.75 - 5.43) - (0)(-12.75 - 0)]}{(442800)(237855) - (0)^2} - \frac{0.325[-348.588 - (-119.738)(0 - 0)][442800(-12.75 - 0) - (0)(24.75 - 5.43)]}{(442800)(237855) - (0)^2}$$

$$v_U = -0.0721 - 0.0655 - 0.0061 = -0.144 \text{ ksi at point A}$$

At the point labeled B in Figure 6, $x_4 = 12.75$ and $y_4 = 24.75$, thus:

$$v_U = \frac{-119.738}{123 * 13.5} + \frac{0.480[3778 - (-119.738)(5.43 - 0)][237855(24.75 - 5.43) - (0)(12.75 - 0)]}{(442800)(237855) - (0)^2} - \frac{0.325[-348.588 - (-119.738)(0 - 0)][442800(12.75 - 0) - (0)(24.75 - 5.43)]}{(442800)(237855) - (0)^2}$$

$$v_U = -0.072 - 0.065 + 0.006 = -0.131 \text{ ksi at point B}$$

At the point labeled C in Figure 6, $x_4 = 12.75$ and $y_4 = -24$, thus:

$$v_U = \frac{-119.738}{123 * 13.5} + \frac{0.480[3778 - (-119.738)(5.43 - 0)][237855(-24 - 5.43) - (0)(12.75 - 0)]}{(442800)(237855) - (0)^2} - \frac{0.325[-348.588 - (-119.738)(0 - 0)][442800(12.75 - 0) - (0)(-24 - 5.43)]}{(442800)(237855) - (0)^2}$$

$$v_U = -0.072 + 0.100 + 0.006 = 0.034 \text{ ksi at point C}$$

At the point labeled D in Figure 6, $x_4 = -12.75$ and $y_4 = -24$, thus:

$$v_U = \frac{-119.738}{123 * 13.5} + \frac{0.480[3778 - (-119.738)(5.43 - 0)][237855(-24 - 5.43) - (0)(-12.75 - 0)]}{(442800)(237855) - (0)^2} - \frac{0.325[-348.588 - (-119.738)(0 - 0)][442800(-12.75 - 0) - (0)(-24 - 5.43)]}{(442800)(237855) - (0)^2}$$

$$v_U = -0.072 + 0.100 - 0.006 = 0.022 \text{ ksi at point D}$$

Point A has the largest absolute value of v_u , thus $v_{\max} = 0.144 \text{ ksi}$

The shear capacity is calculated based on the smallest of ACI 318-95 equations 11-35, 11-36 and 11-37 with the b_0 and d terms removed to convert force to stress.

$$\phi_{vc} = \frac{0.85 \left(2 + \frac{4}{36/12} \right) \sqrt{4000}}{1000} = 0.179 \text{ ksi per equation 11-35}$$

$$\phi_{VC} = \frac{0.85 \left(\frac{30 * 13.5}{123} + 2 \right) \sqrt{4000}}{1000} = 0.285 \text{ ksi per equation 11-36}$$

$$\phi_{VC} = \frac{0.85 * 4 * \sqrt{4000}}{1000} = 0.215 \text{ ksi per equation 11-37}$$

Equation 11-35 yields the smallest value of $\phi_{VC} = 0.179 \text{ ksi}$, and thus this is the shear capacity.

$$\text{Shear Ratio} = \frac{v_u}{\phi_{VC}} = \frac{0.144}{0.179} = 0.802$$

6e. Hand Calculation For Edge Column With Edge Parallel To Y-Axis Using SAFE Method

$$d = [(15 - 1) + (15 - 2)] / 2 = 13.5''$$

Refer to Figure 7.

$$b_0 = 24.75 + 49.5 + 24.75 = 99''$$

$$\gamma_{VX} = 1 - \frac{1}{1 + \left(\frac{2}{3} \right) \sqrt{\frac{49.5}{24.75}}} = 0.485$$

$$\gamma_{VY} = 1 - \frac{1}{1 + \left(\frac{2}{3} \right) \sqrt{\frac{24.75}{49.5}}} = 0.320$$

The coordinates of the center of the column (x_1, y_1) are taken as (0, 0).

The following table is used for calculating the centroid of the critical section for punching shear. Side 1, Side 2 and Side 3 refer to the sides of the critical section for punching shear as identified in Figure 7.

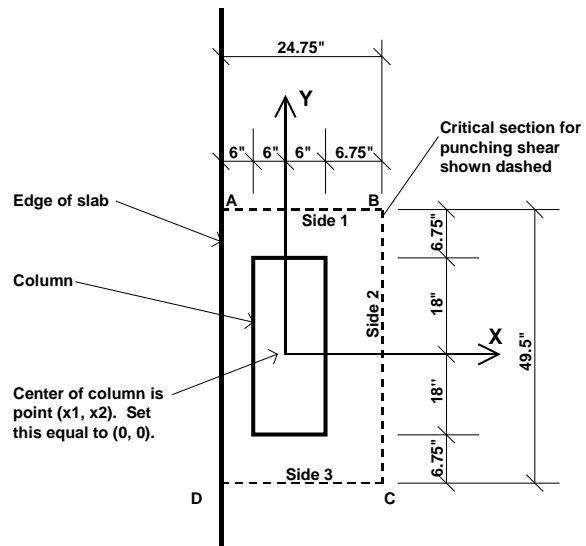

Figure 7: Edge Column With Edge Parallel To Y-Axis, Point 9 in SAFE Model

Item	Side 1	Side 2	Side 3	Sum
x_2	0.375	12.75	0.375	N.A.
y_2	24.75	0	-24.75	N.A.
L	24.75	49.5	24.75	$b_0 = 99$
d	13.5	13.5	13.5	N.A.
Ld	344.125	668.25	344.125	1336.5
Ldx_2	125.30	8520.19	125.30	8770.78
Ldy_2	8269.59	0	-8269.59	0

$$x_3 = \frac{\sum Ldx_2}{Ld} = \frac{8770.78}{1336.5} = 6.56''$$

$$y_3 = \frac{\sum Ldy_2}{Ld} = \frac{0}{1336.5} = 0''$$

The following table is used to calculate I_{XX} , I_{YY} and I_{XY} . The values for I_{XX} , I_{YY} and I_{XY} are given in the column titled "Sum".

Item	Side 1	Side 2	Side 3	Sum
L	24.75	49.5	24.75	N.A.
d	13.5	13.5	13.5	N.A.
$x_2 - x_3$	-6.19	6.19	-6.19	N.A.
$y_2 - y_3$	24.75	0	-24.75	N.A.
Parallel to	X-axis	Y-Axis	X-axis	N.A.
Equations	5a, 6a, 7	5b, 6b, 7	5a, 6a, 7	N.A.
I_{XX}	204672.4	146597.2	204672.4	555942
I_{YY}	34922.6	25584.1	34922.6	95429
I_{XY}	-51168	0	51168	0

From the SAFE output at column point 6:

$$V_U = -94.86 \text{ k}$$

$$M_{UX} = 174.953 \text{ k-in}$$

$$M_{UY} = 1463.801 \text{ k-in}$$

At the point labeled A in Figure 7, $x_4 = -12$ and $y_4 = 24.75$, thus:

$$v_U = \frac{-94.86}{123 * 13.5} + \frac{0.485[174.953 - (-94.86)(0 - 0)][95429(24.75 - 0) - (0)(-12 - 6.56)]}{(555942)(95429) - (0)^2} - \frac{0.320[1463.801 - (-94.86)(6.56 - 0)][555942(-12 - 6.56) - (0)(24.75 - 0)]}{(555942)(95429) - (0)^2}$$

$$v_U = -0.071 + 0.004 + 0.052 = -0.015 \text{ ksi at point A}$$

At the point labeled B in Figure 7, $x_4 = 12.75$ and $y_4 = 24.75$, thus:

$$v_U = \frac{-94.86}{123 * 13.5} + \frac{0.485[174.953 - (-94.86)(0 - 0)][95429(24.75 - 0) - (0)(12.75 - 6.56)]}{(555942)(95429) - (0)^2} - \frac{0.320[1463.801 - (-94.86)(6.56 - 0)][555942(12.75 - 6.56) - (0)(24.75 - 0)]}{(555942)(95429) - (0)^2}$$

$$v_U = -0.071 + 0.004 - 0.017 = -0.084 \text{ ksi at point B}$$

At the point labeled C in Figure 7, $x_4 = 12.75$ and $y_4 = -24.75$, thus:

$$v_U = \frac{-94.86}{123 * 13.5} + \frac{0.485[174.953 - (-94.86)(0 - 0)][95429(-24.75 - 0) - (0)(12.75 - 6.56)]}{(555942)(95429) - (0)^2} - \frac{0.320[1463.801 - (-94.86)(6.56 - 0)][555942(12.75 - 6.56) - (0)(-24.75 - 0)]}{(555942)(95429) - (0)^2}$$

$$v_U = -0.071 - 0.004 - 0.017 = 0.092 \text{ ksi at point C}$$

At the point labeled D in Figure 7, $x_4 = -12$ and $y_4 = -24.75$, thus:

$$v_U = \frac{-94.86}{123 * 13.5} + \frac{0.485[174.953 - (-94.86)(0 - 0)][95429(-24.75 - 0) - (0)(-12 - 6.56)]}{(555942)(95429) - (0)^2} - \frac{0.320[1463.801 - (-94.86)(6.56 - 0)][555942(-12 - 6.56) - (0)(-24.75 - 0)]}{(555942)(95429) - (0)^2}$$

$$v_U = -0.071 - 0.004 + 0.052 = -0.023 \text{ ksi at point D}$$

Point C has the largest absolute value of v_u , thus $v_{\max} = 0.092 \text{ ksi}$

The shear capacity is calculated based on the smallest of ACI 318-95 equations 11-35, 11-36 and 11-37 with the b_0 and d terms removed to convert force to stress.

$$\phi_{VC} = \frac{0.85 \left(2 + \frac{4}{36/12} \right) \sqrt{4000}}{1000} = 0.179 \text{ ksi per equation 11-35}$$

$$\phi_{VC} = \frac{0.85 \left(\frac{30 * 13.5}{99} + 2 \right) \sqrt{4000}}{1000} = 0.327 \text{ ksi per equation 11-36}$$

$$\phi_{VC} = \frac{0.85 * 4 * \sqrt{4000}}{1000} = 0.215 \text{ ksi per equation 11-37}$$

Equation 11-35 yields the smallest value of $\phi_{VC} = 0.179 \text{ ksi}$, and thus this is the shear capacity.

$$\text{Shear Ratio} = \frac{v_u}{\phi_{VC}} = \frac{0.092}{0.179} = 0.515$$

6f. Hand Calculation For Corner Column Using SAFE Method

$$d = [(15 - 1) + (15 - 2)] / 2 = 13.5''$$

Refer to Figure 8.

$$b_0 = 24.75 + 48.75 = 73.5''$$

$$\gamma_{VX} = 1 - \frac{1}{1 + \left(\frac{2}{3} \right) \sqrt{\frac{48.75}{24.75}}} = 0.483$$

$$\gamma_{VY} = 1 - \frac{1}{1 + \left(\frac{2}{3} \right) \sqrt{\frac{24.75}{48.75}}} = 0.322$$

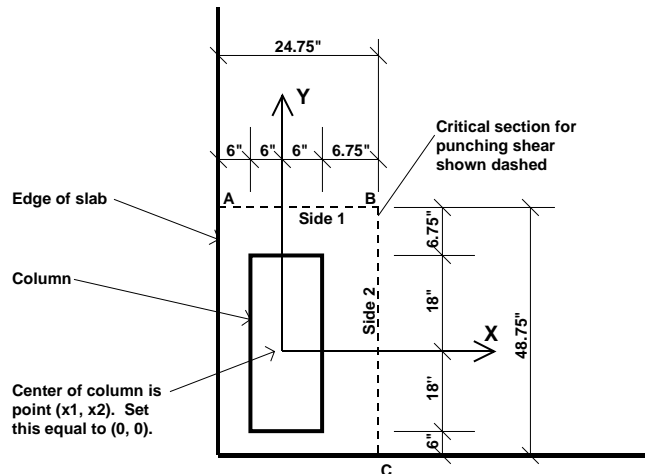

Figure 8: Corner Column, Point 5 in SAFE Model

The coordinates of the center of the column (x_1, y_1) are taken as (0, 0).

The following table is used for calculating the centroid of the critical section for punching shear. Side 1 and Side 2 refer to the sides of the critical section for punching shear as identified in Figure 8.

Item	Side 1	Side 2	Sum
x_2	0.375	12.75	N.A.
y_2	24.75	0.375	N.A.
L	24.75	48.75	$b_0 = 73.5$
d	13.5	13.5	N.A.
Ld	334.125	658.125	992.25
Ldx_2	125.30	8391.09	8516.39
Ldy_2	8269.59	246.80	8516.39

$$x_3 = \frac{\sum Ldx_2}{Ld} = \frac{8516.39}{992.25} = 8.58''$$

$$y_3 = \frac{\sum Ldy_2}{Ld} = \frac{8516.39}{992.25} = 8.58''$$

The following table is used to calculate I_{XX} , I_{YY} and I_{XY} . The values for I_{XX} , I_{YY} and I_{XY} are given in the column titled "Sum".

Item	Side 1	Side 2	Sum
L	24.75	48.75	N.A.
d	13.5	13.5	N.A.
$x_2 - x_3$	-8.21	4.17	N.A.
$y_2 - y_3$	16.17	-8.21	N.A.
Parallel to	X-axis	Y-Axis	N.A.
Equations	5a, 6a, 7	5b, 6b, 7	N.A.
I_{XX}	87332	184673	272005
I_{YY}	44640	11428	56069
I_{XY}	-44338	-22510	-66848

From the SAFE output at column point 5:

$$V_U = -54.696 \text{ k}$$

$$M_{UX} = -1962 \text{ k-in}$$

$$M_{UY} = 1145.68 \text{ k-in}$$

At the point labeled A in Figure 8, $x_4 = -12$ and $y_4 = 24.75$, thus:

$$v_U = \frac{-54.696}{73.5 * 13.5} + \frac{0.483[1962 - (-54.696)(8.58 - 0)][56069(24.75 - 8.58) - (-66848)(-12 - 8.58)]}{(272005)(56069) - (-66848)^2} - \frac{0.322[1145.68 - (-54.696)(8.58 - 0)][272005(-12 - 8.58) - (-66848)(24.75 - 8.58)]}{(272005)(56069) - (-66848)^2}$$

$$v_U = -0.055 + 0.031 + 0.091 = 0.067 \text{ ksi at point A}$$

At the point labeled B in Figure 8, $x_4 = 12.75$ and $y_4 = 24.75$, thus:

$$v_U = \frac{-54.696}{73.5 * 13.5} + \frac{0.483[1962 - (-54.696)(8.58 - 0)][56069(24.75 - 8.58) - (-66848)(12.75 - 8.58)]}{(272005)(56069) - (-66848)^2} - \frac{0.322[1145.68 - (-54.696)(8.58 - 0)][272005(12.75 - 8.58) - (-66848)(24.75 - 8.58)]}{(272005)(56069) - (-66848)^2}$$

$$v_U = -0.055 - 0.079 - 0.045 = -0.179 \text{ ksi at point B}$$

At the point labeled C in Figure 8, $x_4 = 12.75$ and $y_4 = -24$, thus:

$$v_U = \frac{-54.696}{73.5 * 13.5} + \frac{0.483[1962 - (-54.696)(8.58 - 0)][56069(-24 - 8.58) - (-66848)(12.75 - 8.58)]}{(272005)(56069) - (-66848)^2} - \frac{0.322[1145.68 - (-54.696)(8.58 - 0)][272005(12.75 - 8.58) - (-66848)(-24 - 8.58)]}{(272005)(56069) - (-66848)^2}$$

$$v_U = -0.055 + 0.104 + 0.021 = 0.070 \text{ ksi at point C}$$

Point B has the largest absolute value of v_u , thus $v_{\max} = 0.179 \text{ ksi}$

The shear capacity is calculated based on the smallest of ACI 318-95 equations 11-35, 11-36 and 11-37 with the b_0 and d terms removed to convert force to stress.

$$\phi_{vC} = \frac{0.85 \left(2 + \frac{4}{36/12} \right) \sqrt{4000}}{1000} = 0.179 \text{ ksi per equation 11-35}$$

$$\phi_{vC} = \frac{0.85 \left(\frac{20 * 13.5}{73.5} + 2 \right) \sqrt{4000}}{1000} = 0.404 \text{ ksi per equation 11-36}$$

$$\phi_{vC} = \frac{0.85 * 4 * \sqrt{4000}}{1000} = 0.215 \text{ ksi per equation 11-37}$$

Equation 11-35 yields the smallest value of $\phi_{vC} = 0.179 \text{ ksi}$, and thus this is the shear capacity.

$$\text{Shear Ratio} = \frac{v_U}{\phi_{VC}} = \frac{0.179}{0.179} = 1.000$$

6g. Hand Calculation For Corner Column Using SAFE Method Except That I_{XY} Is Set To Zero

This calculation is done for comparison with the corner calculation using the PCA Publication method (Ref. 2). Note that the computer program SAFE does not do the calculation with I_{XY} set to zero.

The calculations in this case are exactly the same as in Section 6f, except that I_{XY} is set to zero. Thus, using the intermediate results in Section 6f we can go right to calculating the stresses.

At the point labeled A in Figure 8, $x_4 = -12$ and $y_4 = 24.75$, thus:

$$v_U = \frac{-54.696}{73.5 * 13.5} + \frac{0.483[1962 - (-54.696)(8.58 - 0)][56069(24.75 - 8.58) - (0)(-12 - 8.58)]}{(272005)(56069) - (0)^2} - \frac{0.322[1145.68 - (-54.696)(8.58 - 0)][272005(-12 - 8.58) - (0)(24.75 - 8.58)]}{(272005)(56069) - (0)^2}$$

$$v_U = -0.055 - 0.043 + 0.080 = -0.018 \text{ ksi at point A}$$

At the point labeled B in Figure 8, $x_4 = 12.75$ and $y_4 = 24.75$, thus:

$$v_U = \frac{-54.696}{73.5 * 13.5} + \frac{0.483[1962 - (-54.696)(8.58 - 0)][56069(24.75 - 8.58) - (0)(12.75 - 8.58)]}{(272005)(56069) - (0)^2} - \frac{0.322[1145.68 - (-54.696)(8.58 - 0)][272005(12.75 - 8.58) - (0)(24.75 - 8.58)]}{(272005)(56069) - (0)^2}$$

$$v_U = -0.055 - 0.043 - 0.016 = -0.114 \text{ ksi at point B}$$

At the point labeled C in Figure 8, $x_4 = 12.75$ and $y_4 = -24$, thus:

$$v_U = \frac{-54.696}{73.5 * 13.5} + \frac{0.483[1962 - (-54.696)(8.58 - 0)][56069(-24 - 8.58) - (0)(12.75 - 8.58)]}{(272005)(56069) - (0)^2} - \frac{0.322[1145.68 - (-54.696)(8.58 - 0)][272005(12.75 - 8.58) - (0)(-24 - 8.58)]}{(272005)(56069) - (0)^2}$$

$$v_U = -0.055 + 0.086 - 0.016 = 0.015 \text{ ksi at point c}$$

Point B has the largest absolute value of v_u , thus $v_{max} = 0.114 \text{ ksi}$

6h. Terminology For PCA Publication Method of Calculating Punching Shear

- a = Distance from center of column to centroid of critical section for punching shear
- A_C = Area of critical section for punching shear
- b_1 = Length of side of critical section for punching shear parallel to Y-axis for bending about X-axis, and parallel to the X-axis for bending about Y-axis
- b_2 = Length of side of critical section for punching shear parallel to X-axis for bending about X-axis, and parallel to the Y-axis for bending about Y-axis
- c = For bending about the X-axis, shorter Y distance from centroid of critical section for punching shear to an edge of the critical section for punching shear that is parallel to the Y-axis. For bending about the Y-axis, shorter X distance from centroid of critical section for punching shear to an edge of the critical section for punching shear that is parallel to the X-axis.
- c' = For bending about the X-axis, longer Y distance from centroid of critical section for punching shear to an edge of the critical section for punching shear that is parallel to the Y-axis. For bending about the Y-axis, longer X distance from centroid of critical section for punching shear to an edge of the critical section for punching shear that is parallel to the X-axis.
- J/c = Section modulus associated with critical section for punching shear
- J/c' = Section modulus associated with critical section for punching shear
- M_{UX} = Moment about line parallel to X-axis at center of column or load
- M_{UY} = Moment about line parallel to Y-axis at center of column or load
- $M_{UXtransformed}$ = Moment about line parallel to X-axis at centroid of critical section for punching shear
- $M_{UYtransformed}$ = Moment about line parallel to Y-axis at centroid of critical section for punching shear
- γ = Percent of M_{UX} resisted by shear per ACI 318-95 equations 11-41 and 13-1

6i. Basic Equation For PCA Publication Method

The basic equation for the PCA Publication method is:

$$v_U = \frac{V_U}{A_C} + \frac{\gamma_X M_{UXtransformed} C_X}{J_X} + \frac{\gamma_Y M_{UYtransformed} C_Y}{J_Y} \quad \text{Eq. 8}$$

Depending on the corner of the critical section for punching shear where you are calculating stress this equation may be in one of the following forms:

$$v_U = \frac{V_U}{A_C} - \frac{\gamma_X M_{UXtransformed} C'_X}{J_X} - \frac{\gamma_Y M_{UYtransformed} C'_Y}{J_Y} \quad \text{Eq. 9}$$

$$v_U = \frac{V_U}{A_C} - \frac{\gamma_X M_{UXtransformed} C'_X}{J_X} + \frac{\gamma_Y M_{UYtransformed} C_Y}{J_Y} \quad \text{Eq. 10}$$

$$v_U = \frac{V_U}{A_c} + \frac{\gamma_{Xx} M_{UXtransformed} C_X}{J_X} - \frac{\gamma_{Yy} M_{UYtransformed} C'_Y}{J_Y} \quad \text{Eq. 11}$$

6j. Hand Calculation For Interior Column Using PCA Publication Method

From the SAFE computer output given in Figure 4 for Point:

$$V_U = -225.707 \text{ k (upward positive)}$$

$$M_{UX} = 464.658 \text{ k-in (right-hand rule)}$$

$$M_{UY} = -419.712 \text{ k-in (right-hand rule)}$$

$$d = [(15 - 1) + (15 - 2)] / 2 = 13.5''$$

To calculate data for bending about X-axis refer to Figure 9. Note that the direction and sign of M_{UX} shown in Figure 15 is consistent with that given in the SAFE output.

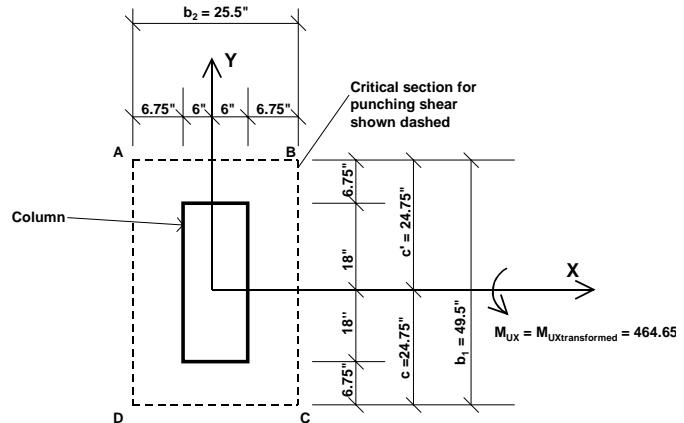

Figure 9: Interior Column, Point 10 in SAFE Model
Bending About X-Axis

$$b_1 = 49.5''$$

$$b_2 = 25.5''$$

$$\gamma_{Xx} = 1 - \frac{1}{1 + \left(\frac{2}{3}\right) \sqrt{\frac{49.5}{25.5}}} = 0.482$$

$$A_c = 2(b_1 + b_2)d = 2 * (49.5 + 25.5) * 13.5 = 2025 \text{ in}^2$$

$$\frac{J_x}{c_x} = \frac{b_1 d (b_1 + 3b_2) + d^3}{3} = \frac{49.5 * 13.5 (49.5 + (3 * 25.5)) + 13.5^3}{3} = 28886.6 \text{ in}^3$$

$$\frac{J_x}{c'_x} = \frac{b_1 d (b_1 + 3b_2) + d^3}{3} = \frac{49.5 * 13.5 (49.5 + (3 * 25.5)) + 13.5^3}{3} = 28886.6 \text{ in}^3$$

$$c_x = \frac{b_1}{2} = \frac{49.5}{2} = 24.75''$$

$$c'_x = \frac{b_1}{2} = \frac{49.5}{2} = 24.75''$$

$$M_{UXtransformed} = M_{UX} = 464.658 \text{ k-in (direction of moment shown in Figure 9)}$$

To calculate data for bending about Y-axis refer to Figure 10. Note that the direction and sign of M_{UY} shown in Figure 10 is consistent with that given in the SAFE output.

$$b_1 = 25.5''$$

$$b_2 = 49.5''$$

$$\gamma_{VY} = 1 - \frac{1}{1 + \left(\frac{2}{3}\right)\sqrt{\frac{25.5}{49.5}}} = 0.324$$

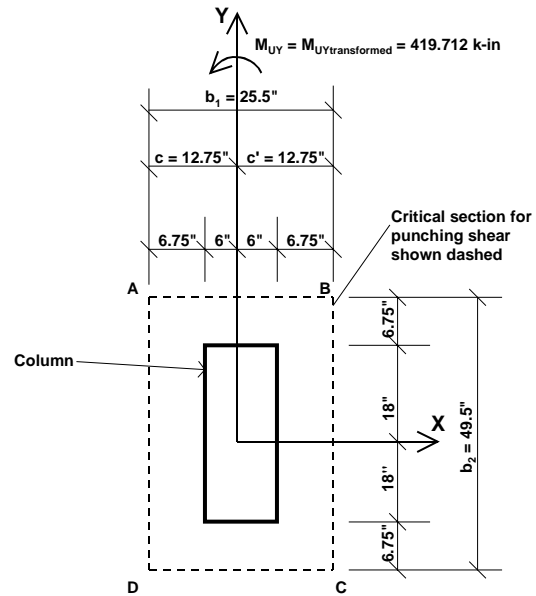

**Figure 10: Interior Column. Point 10 in SAFE Model
Bending About Y-Axis**

$$\frac{J_Y}{c_Y} = \frac{b_1 d (b_1 + 3b_2) + d^3}{3} = \frac{25.5 * 13.5 (25.5 + (3 * 49.5)) + 13.5^3}{3} = 20786.6 \text{ in}^3$$

$$\frac{J_y}{c'_y} = \frac{b_1 d (b_1 + 3b_2) + d^3}{3} = \frac{25.5 * 13.5 (25.5 + (3 * 49.5)) + 13.5^3}{3} = 20786.6 \text{ in}^3$$

$$c_Y = \frac{b_1}{2} = \frac{25.5}{2} = 12.75''$$

$$c'_x = \frac{b_1}{2} = \frac{25.5}{2} = 12.75''$$

$M_{UYtransformed} = M_{UY} = 419.712 \text{ k-in}$ (direction of moment shown in Figure 10)

The punching shear stress at point A in Figures 9 and 10 is calculated using equation 10:

$$v_{vu} = \frac{225.707}{2025} - \frac{0.482 * 464.658}{28886.6} + \frac{0.324 * 419.712}{20786.6} = 0.111 - .008 + .007 = 0.110 \text{ ksi}$$

The punching shear stress at point B in Figures 9 and 10 is calculated using equation 9:

$$v_{vu} = \frac{225.707}{2025} - \frac{0.482 * 464.658}{28886.6} - \frac{0.324 * 419.712}{20786.6} = 0.111 - .008 - .007 = 0.096 \text{ ksi}$$

The punching shear stress at point C in Figures 9 and 10 is calculated using equation 11:



$$c_Y = \frac{b_1}{2} = \frac{25.5}{2} = 12.75''$$

$$c'_Y = \frac{b_1}{2} = \frac{25.5}{2} = 12.75''$$

$M_{UY\text{transformed}} = M_{UY} = 348.588 \text{ k-in}$ (direction of moment shown in Figure 12)

The punching shear stress at point A in Figures 11 and 12 is calculated using equation 8:

$$v_u = \frac{119.738}{1660.5} + \frac{0.480 * 3128}{22917.3} + \frac{0.325 * 348.588}{18655.3} = 0.072 + .066 + .006 = 0.144 \text{ ksi}$$

The punching shear stress at point B in Figures 11 and 12 is calculated using equation 11:

$$v_u = \frac{119.738}{1660.5} + \frac{0.480 * 3128}{22917.3} - \frac{0.325 * 348.588}{18655.3} = 0.072 + .066 - .006 = 0.132 \text{ ksi}$$

The punching shear stress at point C in Figures 11 and 12 is calculated using equation 9:

$$v_u = \frac{119.738}{1660.5} - \frac{0.480 * 3128}{15046.7} - \frac{0.325 * 348.588}{18655.3} = 0.072 - .100 - .006 = -0.034 \text{ ksi}$$

The punching shear stress at point D in Figures 11 and 12 is calculated using equation 10:

$$v_u = \frac{119.738}{1660.5} - \frac{0.480 * 3128}{15046.7} + \frac{0.325 * 348.588}{18655.3} = 0.072 - .100 + .006 = -0.022 \text{ ksi}$$

Point A has the largest absolute value of v_u , thus $v_{\max} = 0.144 \text{ ksi}$

6l. Hand Calculation For Edge Column With Edge Parallel To Y-Axis Using PCA Publication Method

From the SAFE computer output given in Figure 4 for Point 9:

$$V_U = -94.86 \text{ k (upward positive)}$$

$$M_{UX} = 174.953 \text{ k-in (right-hand rule)}$$

$$M_{UY} = 1463.801 \text{ k-in (right-hand rule)}$$

$$d = [(15 - 1) + (15 - 2)] / 2 = 13.5''$$

To calculate data for bending about X-axis refer to Figure 13. Note that the direction and sign of M_{UX} shown in Figure 13 is consistent with that given in the SAFE output. Also note that X-direction bending is bending parallel to the edge.

$$b_1 = 49.5''$$

$$b_2 = 24.75''$$

$$\gamma_{VX} = 1 - \frac{1}{1 + \left(\frac{2}{3}\right) \sqrt{\frac{49.5}{24.75}}} = 0.485$$

$$A_C = (b_1 + 2b_2)d$$

$$= (49.5 + (2 * 24.75)) * 13.5$$

$$= 1336.5 \text{ in}^2$$

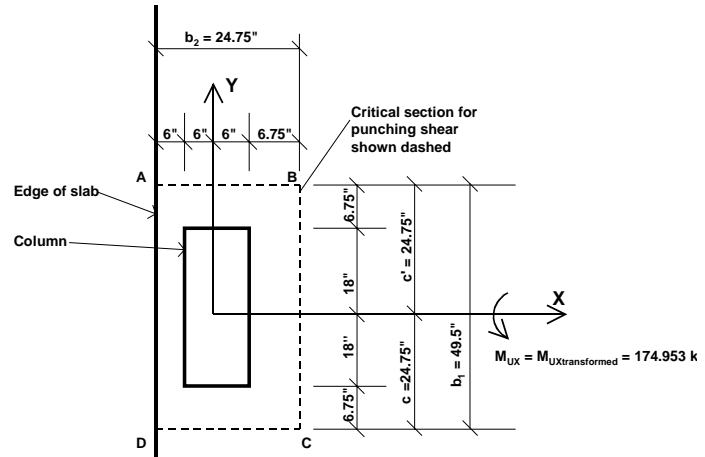

Figure 13: Edge Column With Edge Parallel To Y-Axis
Point 9 in SAFE Model, Bending About X-Axis

$$\frac{J_X}{c_X} = \frac{b_1 d (b_1 + 6b_2) + d^3}{6} = \frac{49.5 * 13.5 (49.5 + (6 * 24.75)) + 13.5^3}{6} = 22462.3 \text{ in}^3$$

$$\frac{J_X}{c'_X} = \frac{b_1 d (b_1 + 6b_2) + d^3}{6} = \frac{49.5 * 13.5 (49.5 + (6 * 24.75)) + 13.5^3}{6} = 22462.3 \text{ in}^3$$

$$c_X = \frac{b_1}{2} = \frac{49.5}{2} = 24.75''$$

$$c'_X = \frac{b_1}{2} = \frac{49.5}{2} = 24.75''$$

$M_{UXtransformed} = M_{UX} = 174.953 \text{ k-in}$ (direction of moment shown in Figure 13)

To calculate data for bending about Y-axis refer to Figure 14. Note that the direction and sign of M_{UY} shown in Figure 14 is consistent with that given in the SAFE output. Also note that Y-direction bending is bending perpendicular to the edge.

$$b_1 = 24.75''$$

$$b_2 = 49.5''$$

$$\gamma_{VY} = 1 - \frac{1}{1 + \left(\frac{2}{3}\right) \sqrt{\frac{24.75}{49.5}}} = 0.320$$

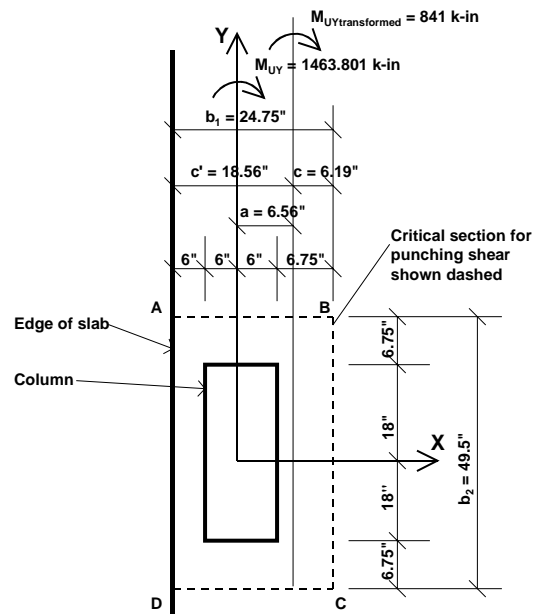

Figure 14: Edge Column With Edge Parallel To Y-Axis
Point 6 in SAFE Model, Bending About Y-Axis

$$\frac{J_Y}{c_Y} = \frac{2b_1^2 d(b_1 + 2b_2) + d^3(2b_1 + b_2)}{6b_1} = \frac{2 * 24.75^2 * 13.5(24.75 + (2 * 49.5)) + 13.5^3((2 * 24.75) + 49.5)}{6 * 24.75} = 15422.9 \text{ in}^3$$

$$\frac{J_Y}{c'_Y} = \frac{2b_1^2 d(b_1 + 2b_2) + d^3(2b_1 + b_2)}{6(b_1 + b_2)} = \frac{2 * 24.75^2 * 13.5(24.75 + (2 * 49.5)) + 13.5^3((2 * 24.75) + 49.5)}{6 * (24.75 + 49.5)} = 5141.0 \text{ in}^3$$

$$c_Y = \frac{b_1^2}{2b_1 + b_2} = \frac{24.75^2}{(2 * 24.75) + 49.5} = 6.19''$$

$$c'_Y = \frac{b_1(b_1 + b_2)}{2b_1 + b_2} = \frac{24.75 * (24.75 + 49.5)}{(2 * 24.75) + 49.5} = 18.56''$$

$$a_Y = 6 + 6.75 - 6.19 = 6.56''$$

$$M_{UY\text{transformed}} = 1463.801 - 94.86 * 6.56 = 841 \text{ k-in (direction of moment shown in Figure 14)}$$

The punching shear stress at point A in Figures 13 and 14 is calculated using equation 9:

$$v_U = \frac{94.86}{1336.5} - \frac{0.485 * 174.953}{22462.3} - \frac{0.320 * 841}{5141.0} = 0.071 - .004 - .052 = 0.015 \text{ ksi}$$

The punching shear stress at point B in Figures 13 and 14 is calculated using equation 10:

$$v_U = \frac{94.86}{1336.5} - \frac{0.485 * 174.953}{22462.3} + \frac{0.320 * 841}{15422.9} = 0.071 - .004 + .017 = 0.084 \text{ ksi}$$

The punching shear stress at point C in Figures 13 and 14 is calculated using equation 8:

$$v_U = \frac{94.86}{1336.5} + \frac{0.485 * 174.953}{22462.3} + \frac{0.320 * 841}{15422.9} = 0.071 + .004 + .017 = 0.092 \text{ ksi}$$

The punching shear stress at point D in Figures 13 and 14 is calculated using equation 11:

$$v_U = \frac{94.86}{1336.5} + \frac{0.485 * 174.953}{22462.3} - \frac{0.320 * 841}{5141.0} = 0.071 + .004 - .052 = 0.023 \text{ ksi}$$

Point C has the largest absolute value of v_u , thus $v_{\max} = 0.092 \text{ ksi}$

6m. Hand Calculation For Corner Column Using PCA Publication Method

From the SAFE computer output given in Figure 4 for Point 5:

$$V_U = -54.696 \text{ k (upward positive)}$$

$$M_{UX} = -1962 \text{ k-in (right-hand rule)}$$

$$M_{UY} = 1145.68 \text{ k-in (right-hand rule)}$$

$$d = [(15 - 1) + (15 - 2)] / 2 = 13.5''$$

To calculate data for bending about X-axis refer to Figure 15. Note that the direction and sign of M_{UX} shown in Figure 15 is consistent with that given in the SAFE output.

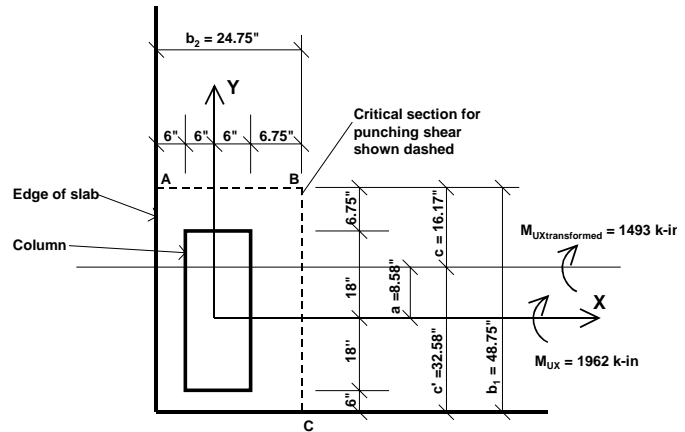

Figure 15: Corner Column, Point 5 in SAFE Model
Bending About X-Axis

$$b_1 = 48.75''$$

$$b_2 = 24.75''$$

$$\gamma_{KX} = 1 - \frac{1}{1 + \left(\frac{2}{3}\right)\sqrt{\frac{48.75}{24.75}}} = 0.483$$

$$A_C = (b_1 + b_2)d = (48.75 + 24.75) * 13.5 = 992.25 \text{ in}^2$$

$$\frac{J_X}{c_X} = \frac{b_1^2 d(b_1 + 4b_2) + d^3(b_1 + b_2)}{6b_1} = \frac{48.75^2 * 13.5(48.75 + (4 * 24.75)) + 13.5^3(48.75 + 24.75)}{6 * 48.75} = 16824.6 \text{ in}^3$$

$$\frac{J_X}{c'_X} = \frac{b_1^2 d(b_1 + 4b_2) + d^3(b_1 + b_2)}{6(b_1 + 2b_2)} = \frac{48.75^2 * 13.5(48.75 + (4 * 24.75)) + 13.5^3(48.75 + 24.75)}{6 * (48.75 + (2 * 24.75))} = 8348.1 \text{ in}^3$$

$$c_X = \frac{b_1^2}{2(b_1 + b_2)} = \frac{48.75^2}{2 * (48.75 + 24.75)} = 16.17''$$

$$c'_X = \frac{b_1(b_1 + 2b_2)}{2(b_1 + b_2)} = \frac{48.75 * (48.75 + (2 * 24.75))}{2 * (48.75 + 24.75)} = 32.58''$$

$$a_X = 18 + 6.75 - 16.17 = 8.58''$$

$$M_{UXtransformed} = 1962 - 54.696 * 8.58 = 1493 \text{ k-in (direction of moment shown in Figure 15)}$$

To calculate data for bending about Y-axis refer to Figure 16. Note that the direction and sign of M_{UY} shown in Figure 16 is consistent with that given in the SAFE output.

$$b_1 = 24.75''$$

$$b_2 = 48.75''$$

$$\gamma_{YV} = 1 - \frac{1}{1 + \left(\frac{2}{3}\right) \sqrt{\frac{24.75}{48.75}}} = 0.322$$

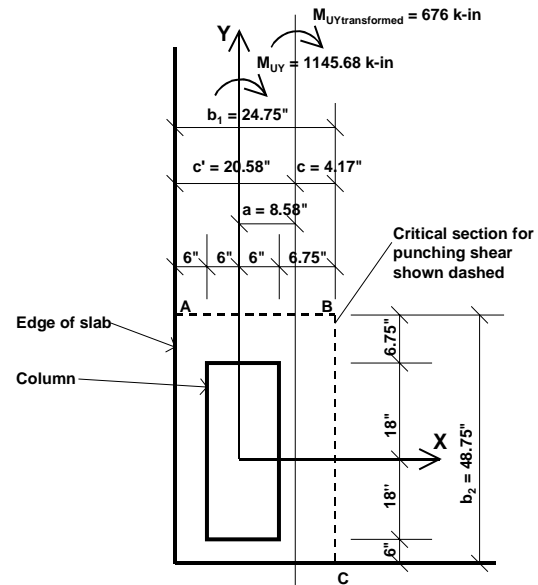

Figure 16: Corner Column, Point 5 in SAFE Model Bending About Y-Axis

$$\frac{J_Y}{c_Y} = \frac{b_1^2 d (b_1 + 4b_2) + d^3 (b_1 + b_2)}{6b_1} = \frac{24.75^2 * 13.5(24.75 + (4 * 48.75)) + 13.5^3 (24.75 + 48.75)}{6 * 24.75} = 13455.1 \text{ in}^3$$

$$\frac{J_y}{c'_y} = \frac{b_1^2 d (b_1 + 4b_2) + d^3 (b_1 + b_2)}{6(b_1 + 2b_2)} = \frac{24.75^2 * 13.5(24.75 + (4 * 48.75)) + 13.5^3 (24.75 + 48.75)}{6 * (24.75 + (2 * 48.75))} = 2724.0 \text{ in}^3$$

$$c_Y = \frac{b_1^2}{2(b_1 + b_2)} = \frac{24.75^2}{2 * (24.75 + 48.75)} = 4.17''$$

$$c'_x = \frac{b_1(b_1 + 2b_2)}{2(b_1 + b_2)} = \frac{24.75 * (24.75 + (2 * 48.75))}{2 * (48.75 + 24.75)} = 20.58''$$

$$a_Y = 6 + 6.75 - 4.17 = 8.58''$$

$$M_{UYtransformed} = 1145.68 - 54.696 * 8.58 = 676 \text{ k-in (direction of moment shown in Figure 16)}$$

The punching shear stress at point A in Figures 15 and 16 is calculated using equation 11:



$$v_u = \frac{54.696}{992.25} + \frac{0.483 * 1493}{16824.6} - \frac{0.322 * 676}{2724.0} = 0.055 + .043 - .080 = 0.018 \text{ ksi}$$

The punching shear stress at point B in Figures 15 and 16 is calculated using equation 8:

$$v_u = \frac{54.696}{992.25} + \frac{0.483 * 1493}{16824.6} + \frac{0.322 * 676}{13455.1} = 0.055 + .043 + .016 = 0.114 \text{ ksi}$$

The punching shear stress at point C in Figures 15 and 16 is calculated using equation 10:

$$v_u = \frac{54.696}{992.25} - \frac{0.483 * 1493}{8348.1} + \frac{0.322 * 676}{2724.0} = 0.055 - .086 + .016 = -0.018 \text{ ksi}$$

Point B has the largest absolute value of v_u , thus $v_{max} = 0.114 \text{ ksi}$

6n. Comparison Of Punching Shear Stress Results

A comparison of the punching shear stress results is shown in the table below. The hand calculations using the SAFE method yield results the same as the SAFE computer model for all cases, that is for the interior column, the edge column with the edge parallel to the X-axis, the edge column with the edge parallel to the Y-axis and the corner column. The hand calculations using the PCA Publication method (Ref. 2) yield results the same as the SAFE computer model (and SAFE hand calculations) for all cases except the corner column. For the corner column if the I_{XY} term in the hand calculations using the SAFE method is set to zero, then this calculation yields the same result as the hand calculation using the PCA method.

Punching Shear Stress Results, ksi			
Column Type	SAFE Computer Model	Hand Calculation Using SAFE Method	Hand Calculation Using PCA Publication Method
Interior	0.126	0.126	0.126
Edge parallel to X-axis	0.144	0.144	0.144
Edge parallel to Y-axis	0.144	0.144	0.144
Corner	0.179	0.179	0.114
Corner with $I_{XY} = 0$	N. A.	0.114	N. A.